

PLANTA DESARENADOR
ESCALA 1:50

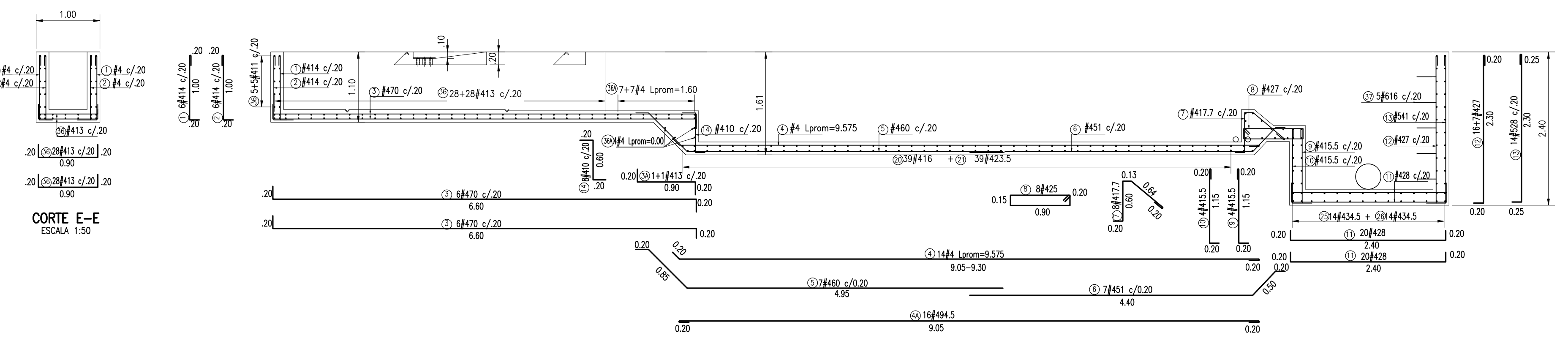

CORTE A-A
ESCALA 1:50

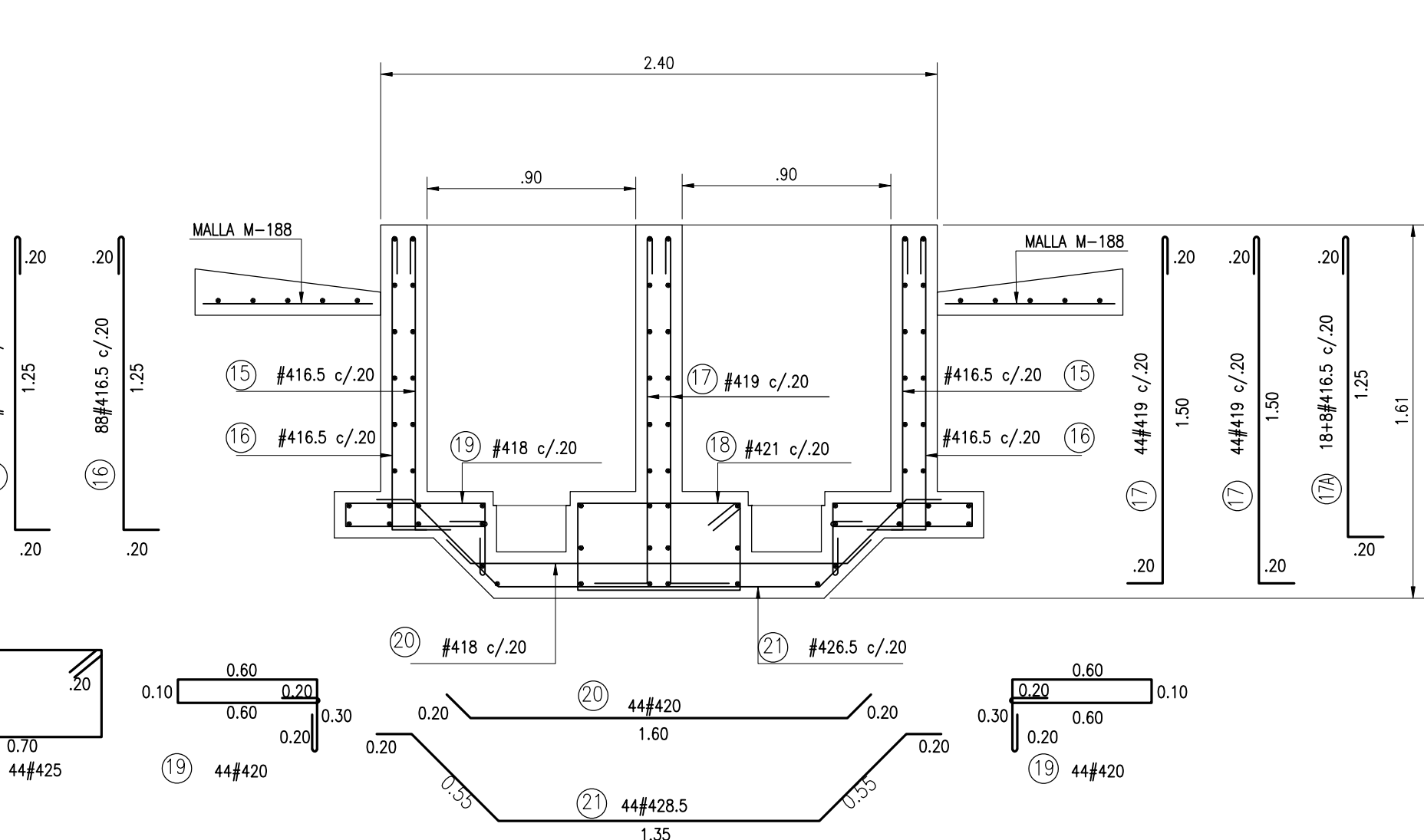

CORTE C-C
ESCALA 1:25

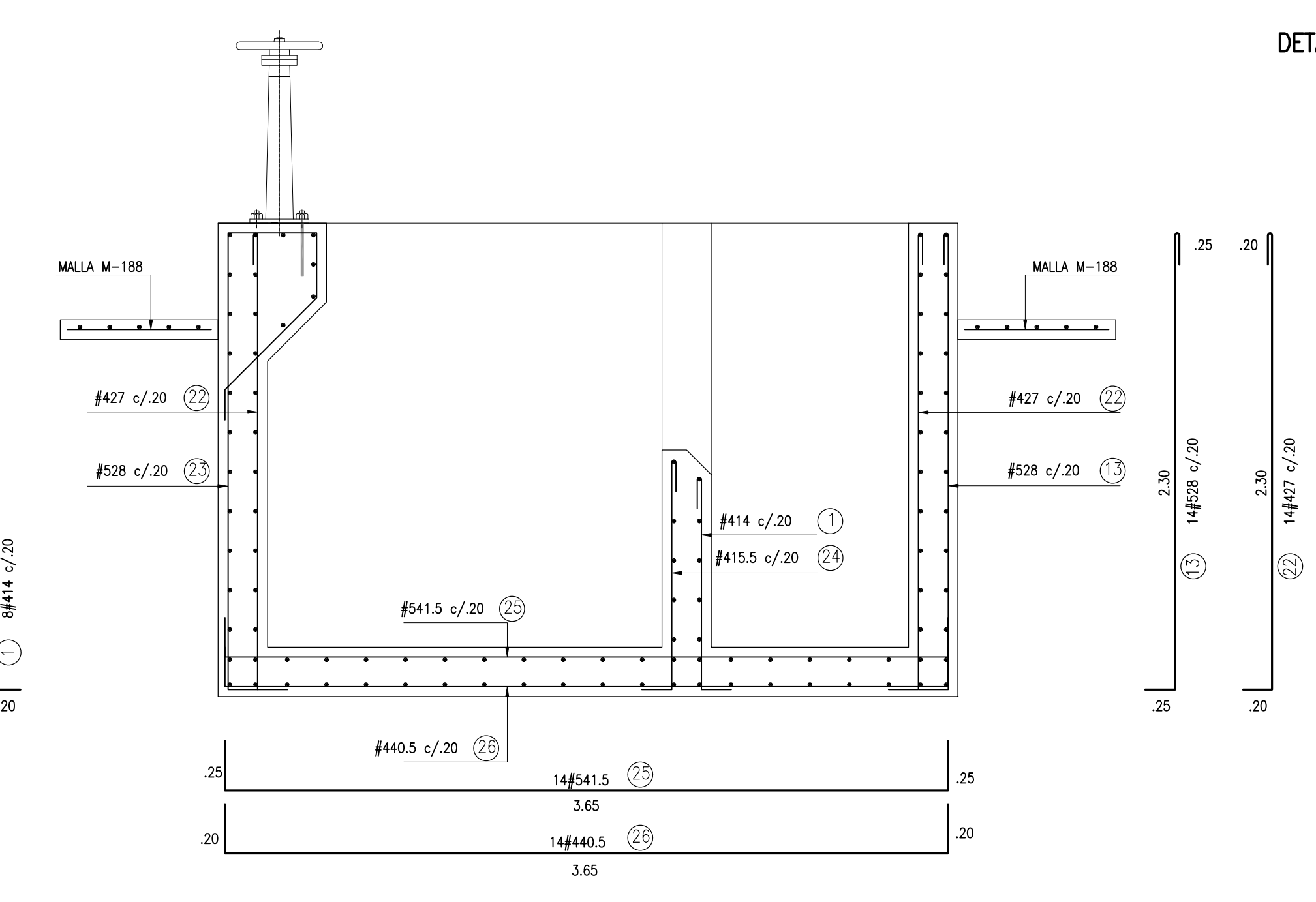

CORTE B-B
ESCALA 1:25

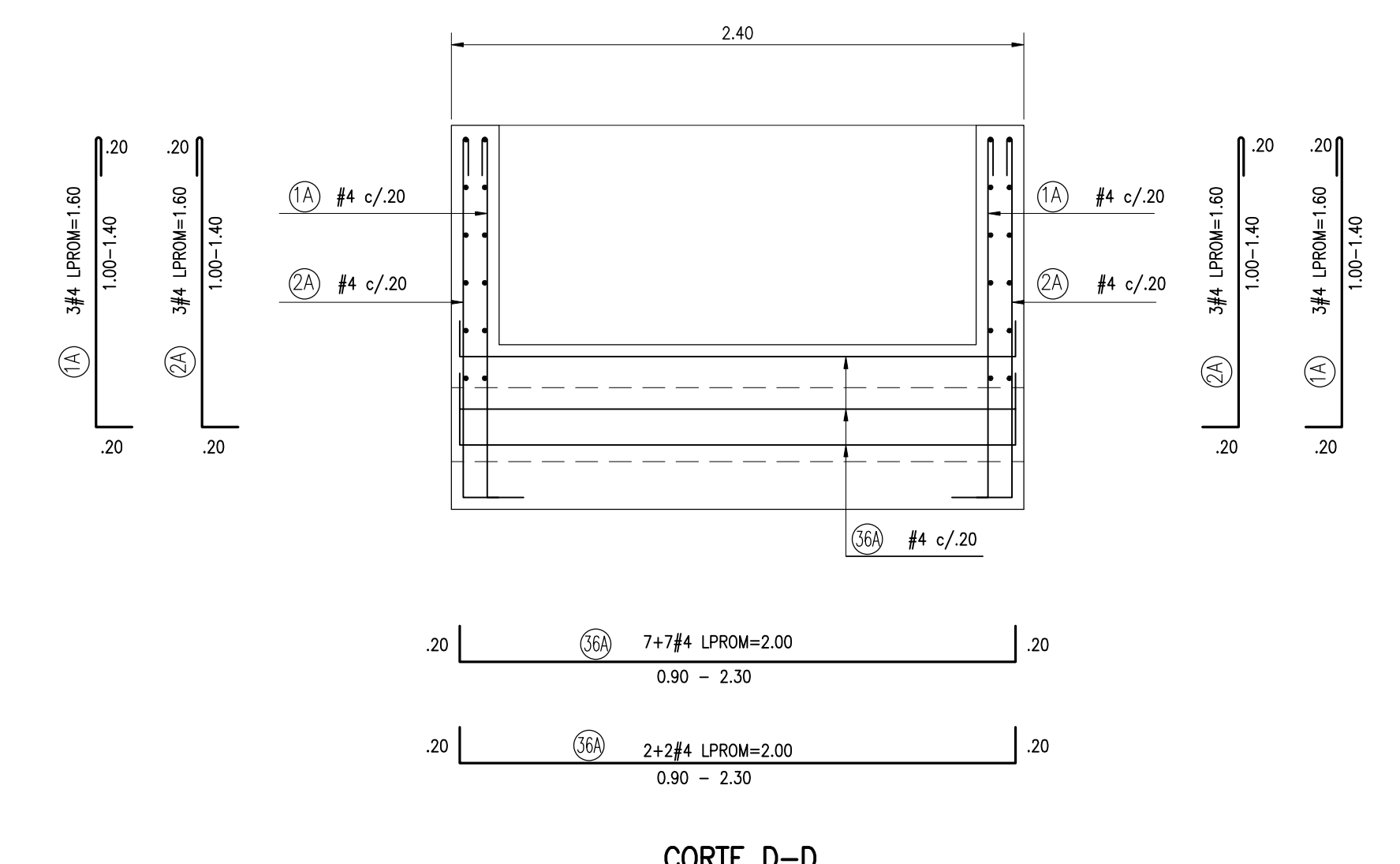

CORTE D-D
ESCALA 1:25

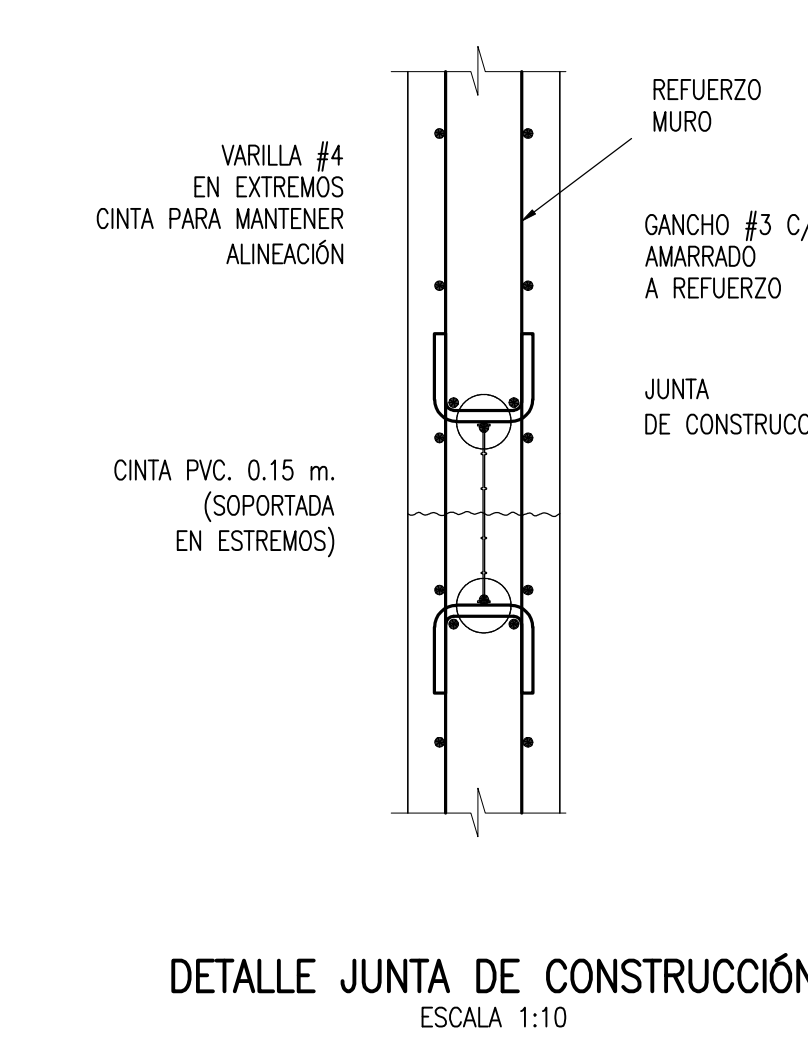

DETALLE JUNTA DE CONSTRUCCION
ESCALA 1:10

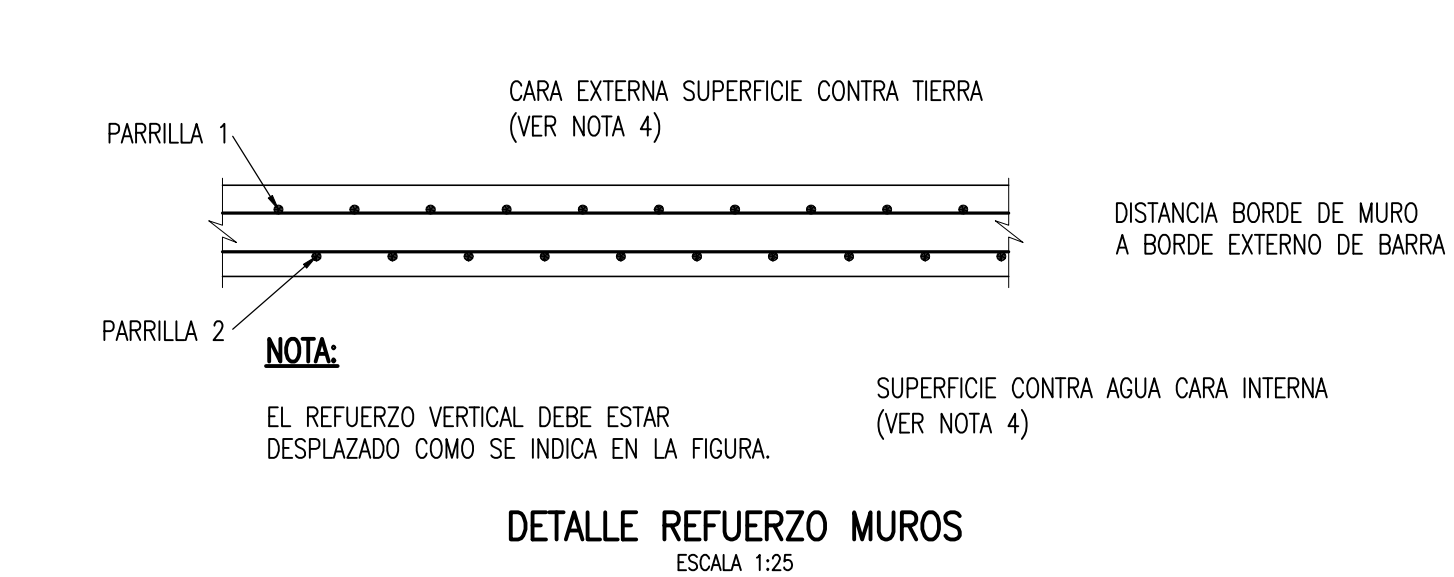

DETALLE REFUERZO MUROS
ESCALA 1:25

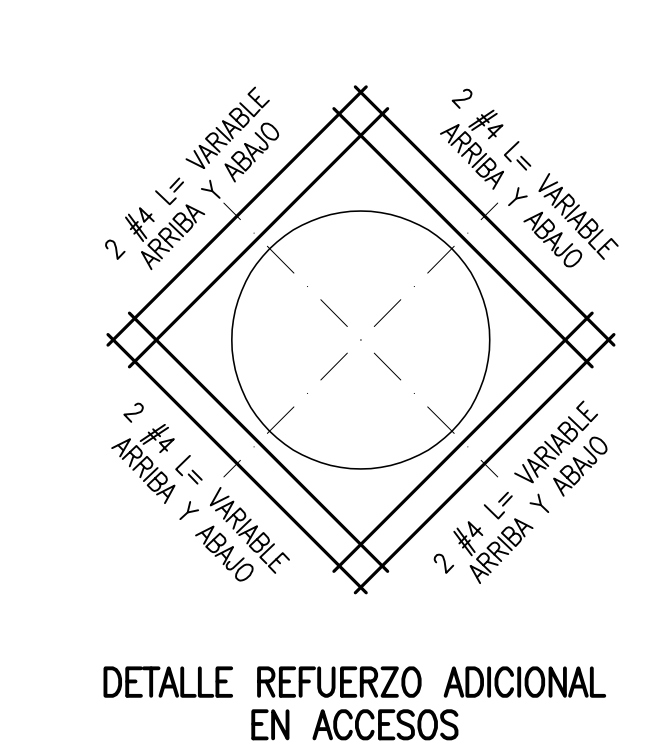

DETALLE REFUERZO ADICIONAL EN ACCESOS
ESCALA 1:25

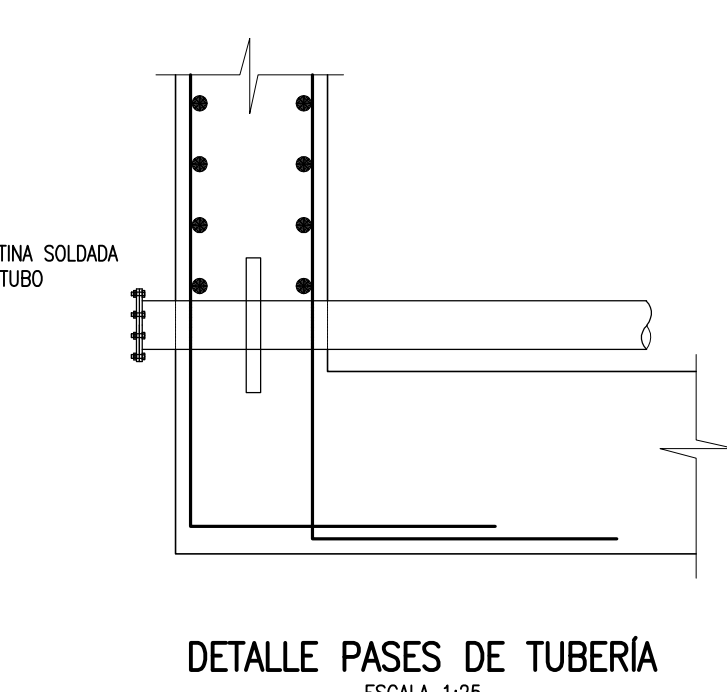

DETALLE PASES DE TUBERIA
ESCALA 1:25

| CUADRO DE HIERROS | | | | |
|-------------------|----------|---------------------|-----------|-------|
| DESIGNACION | DIAMETRO | FIGURACION | LONG. (m) | CANT. |
| 1 | Nº4 | 1.00 0.20 | 1.40 | 58 |
| 2 | Nº4 | VAR 0.20 | 1.40 | 6 |
| 3 | Nº4 | 1.00 0.20 | 1.40 | 58 |
| 4 | Nº4 | VAR 0.20 | 1.40 | 6 |
| 5 | Nº4 | 6.60 0.20 | 7.00 | 12 |
| 6 | Nº4 | 0.90 0.20 | 1.30 | 4 |
| 7 | Nº4 | 9.05-9.30 0.20 | 9.70 | 14 |
| 8 | Nº4 | 0.20 9.05 0.20 | 9.45 | 16 |
| 9 | Nº4 | 0.20 0.65 4.95 | 6.00 | 7 |
| 10 | Nº4 | 0.20 0.50 4.40 | 5.10 | 7 |
| 11 | Nº4 | 0.20 1.15 0.60 0.20 | 1.77 | 8 |
| 12 | Nº4 | 0.20 0.90 0.20 | 2.50 | 8 |
| 13 | Nº4 | 0.20 1.15 0.20 | 1.55 | 6 |
| 14 | Nº4 | 0.20 1.15 0.20 | 1.55 | 6 |
| 15 | Nº4 | 0.20 2.40 0.20 | 2.80 | 40 |
| 16 | Nº4 | 0.20 2.30 0.20 | 2.70 | 23 |
| 17 | Nº5 | 0.20 0.25 | 2.80 | 11 |
| 18 | Nº4 | 0.20 0.60 0.20 | 1.00 | 8 |
| 19 | Nº4 | 0.20 1.25 0.20 | 1.65 | 88 |
| 20 | Nº4 | 0.20 1.25 0.20 | 1.65 | 88 |
| 21 | Nº4 | 0.20 1.50 0.20 | 1.90 | 88 |
| 22 | Nº4 | 0.20 1.25 0.20 | 1.65 | 26 |
| 23 | Nº4 | 0.20 0.70 0.20 | 2.50 | 44 |
| 24 | Nº4 | 0.10 0.60 0.20 0.30 | 2.00 | 44 |
| 25 | Nº4 | 0.20 1.60 0.20 | 2.00 | 44 |
| 26 | Nº4 | 0.20 0.20 1.35 0.20 | 2.85 | 44 |
| 27 | Nº4 | 0.20 2.30 0.20 | 2.70 | 14 |
| 28 | Nº5 | 0.20 0.25 | 4.20 | 6 |
| 29 | Nº4 | 0.20 1.15 0.20 | 1.55 | 8 |
| 30 | Nº5 | 0.20 3.65 0.20 | 4.15 | 14 |
| 31 | Nº4 | 0.20 3.65 0.20 | 4.05 | 14 |
| 32 | Nº4 | 0.20 5.40 0.20 | 5.80 | 10 |
| 33 | Nº4 | 0.20 1.90 5.15 0.20 | 7.45 | 10 |
| 34 | Nº4 | 0.20 2.30 0.20 | 7.50 | 12 |
| 35 | Nº4 | 0.20 5.30 0.20 | 5.50 | 12 |
| 36 | Nº4 | 0.20 1.10 9.15 0.20 | 10.65 | 12 |
| 37 | Nº4 | 0.20 0.30 3.20 0.20 | 3.95 | 22 |
| 38 | Nº4 | 0.20 2.35 0.20 | 2.75 | 11 |
| 39 | Nº4 | 0.20 2.40 0.20 | 2.80 | 11 |
| 40 | Nº4 | 0.20 9.45 0.20 | 9.85 | 12 |
| 41 | Nº4 | 0.20 3.65 0.20 | 4.05 | 12 |
| 42 | Nº4 | 0.20 3.65 0.20 | 4.05 | 33 |
| 43 | Nº4 | 0.20 0.90 0.20 | 1.30 | 12 |
| 44 | Nº5 | 0.20 0.40 0.20 | 1.60 | 6 |

NOTAS:
 CONCRETO f'c: 28 MPa= 28.80 m³
 ACERO fy: 420 MPa= 2070 kg
 PESO DEL CONCRETO
 3/4"=21.3 kg
 5/8"=17.7 kg
 1/2"=12.7 kg

| | INTERVENOR: | LOCALIZACIÓN: | PUNTO DE AMARRE: MOMPOS 1: NORTE-961.931.844 ESTE: 513.858.232 COTA: 19,554 msnm MOMPOS 2: NORTE-961.196.014 ESTE: 513.561.903 COTA: 19,705 msnm | MODIFICACIONES <table border="1"> <tr><th>FECHA</th><th>MODIFICACION</th><th>NOMBRE ING. RESPONSABLE</th><th>FIRMA</th></tr> <tr><td>01-12-10</td><td>REV 0.</td><td>ING. ROBERTO MERCHAN</td><td></td></tr> <tr><td>01-02-11</td><td>REV 1.</td><td>ING. ROBERTO MERCHAN</td><td></td></tr> <tr><td>15-03-11</td><td>REV 2.</td><td>ING. ROBERTO MERCHAN</td><td></td></tr> </table> | FECHA | MODIFICACION | NOMBRE ING. RESPONSABLE | FIRMA | 01-12-10 | REV 0. | ING. ROBERTO MERCHAN | | 01-02-11 | REV 1. | ING. ROBERTO MERCHAN | | 15-03-11 | REV 2. | ING. ROBERTO MERCHAN | | OBJETO: ELABORACION Y ENTREGA DE ESTUDIOS Y DISEÑOS PARA PROYECTOS DE ACUEDUCTO, SANIAMIENTO BASICO Y PREVENCIÓN Y ATENCIÓN DE EMERGENCIAS EN EL MARCO DE LOS PLANES DEPARTAMENTALES DE AGUA EN EL DEPARTAMENTO BOLIVAR | MUNICIPIO DE MOMPOS DEPARTAMENTO DE BOLIVAR REPUBLICA DE COLOMBIA | PROYECTO N° : 973 FECHA: 15-03-11 PLANO No. 4/8 |
|--|---|----------------------|--|--|---|--------------|-------------------------|-------|----------|--------|----------------------|--|----------|--------|----------------------|--|----------|--------|----------------------|--|--|---|---|
| | FECHA | MODIFICACION | NOMBRE ING. RESPONSABLE | FIRMA | | | | | | | | | | | | | | | | | | | |
| 01-12-10 | REV 0. | ING. ROBERTO MERCHAN | | | | | | | | | | | | | | | | | | | | | |
| 01-02-11 | REV 1. | ING. ROBERTO MERCHAN | | | | | | | | | | | | | | | | | | | | | |
| 15-03-11 | REV 2. | ING. ROBERTO MERCHAN | | | | | | | | | | | | | | | | | | | | | |
| DIRECTOR: ING. SERGIO MCGOLLON M. MAJ. - P ESPECIALISTA ING. ROBERTO MERCHAN MAJ. 25202-20985 - CND | CONTRATO No. 266-2009 INTERVENCIÓN CONTRATO No. 266-2009 ESTUDIOS TÉCNICOS Y CONSTRUCCIONES LTDA | SIN ESCALA | DISEÑO ESTRUCTURAL | ESCALA: INDICADAS | NOMBRE DEL ARCHIVO: 973-BL-04ESPTAR003.dwg | | | | | | | | | | | | | | | | | | |